

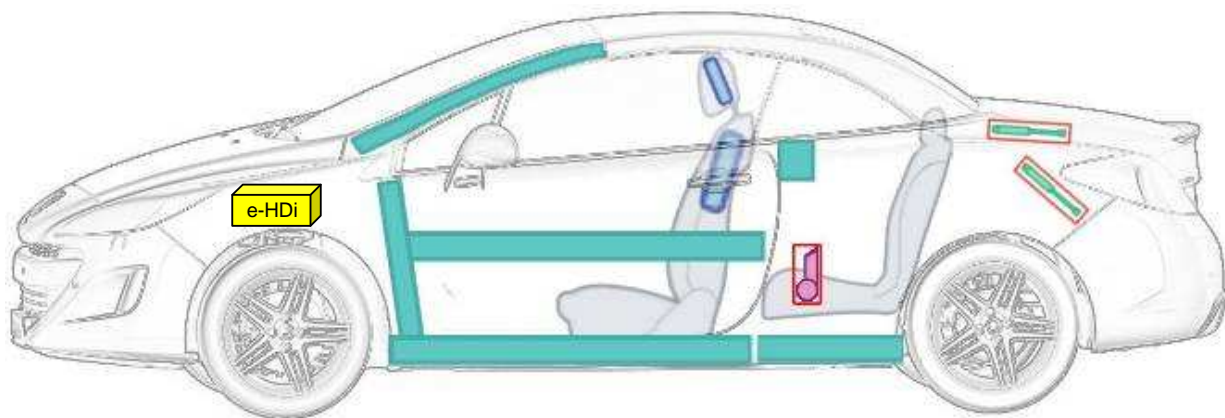

Peugeot 308 cc (ab 2008)

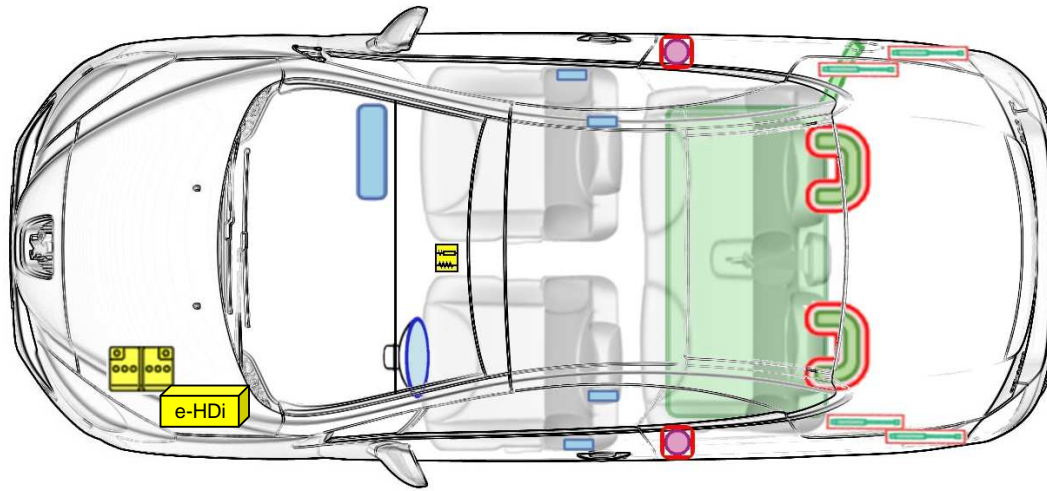

Legende

	Airbag		Karosserie- verstärkung		Batterie		Steuergerät
	Gas- generator		Gurtstraffer		Überroll- schutz		Gasdruck- dämpfer
	Gastank		Sicherheits- -ventil		Kraftstoff- tank		e-Booster
	Sicherungs- kasten		Hochvolt- -leitung/ -komponenten		Hochvolt- -batterie		Hochvolt- trennstelle



Peugeot 308 cc (ab 2008)

• Kommentare:

- Aktive Überrollbügel integriert in den hinteren Kopfstützen, Aktivierung erfolgt über eine Feder mit pyrotechnische Auslösung
- Das Dach kann manuell geöffnet werden (mit Imbus-Schlüssel) durch Zugriff auf das hydraulische System im Kofferraum (siehe Foto). Anschließend muss die Verriegelung im Fahrzeuginnen über dem Rückspiegel entriegelt werden.
- Erhebliche Verstärkung des A-Pfeilers und des unteren Karosseriebereichs, die einen Eingriff im Vergleich zu den anderen Versionen erschwert

