

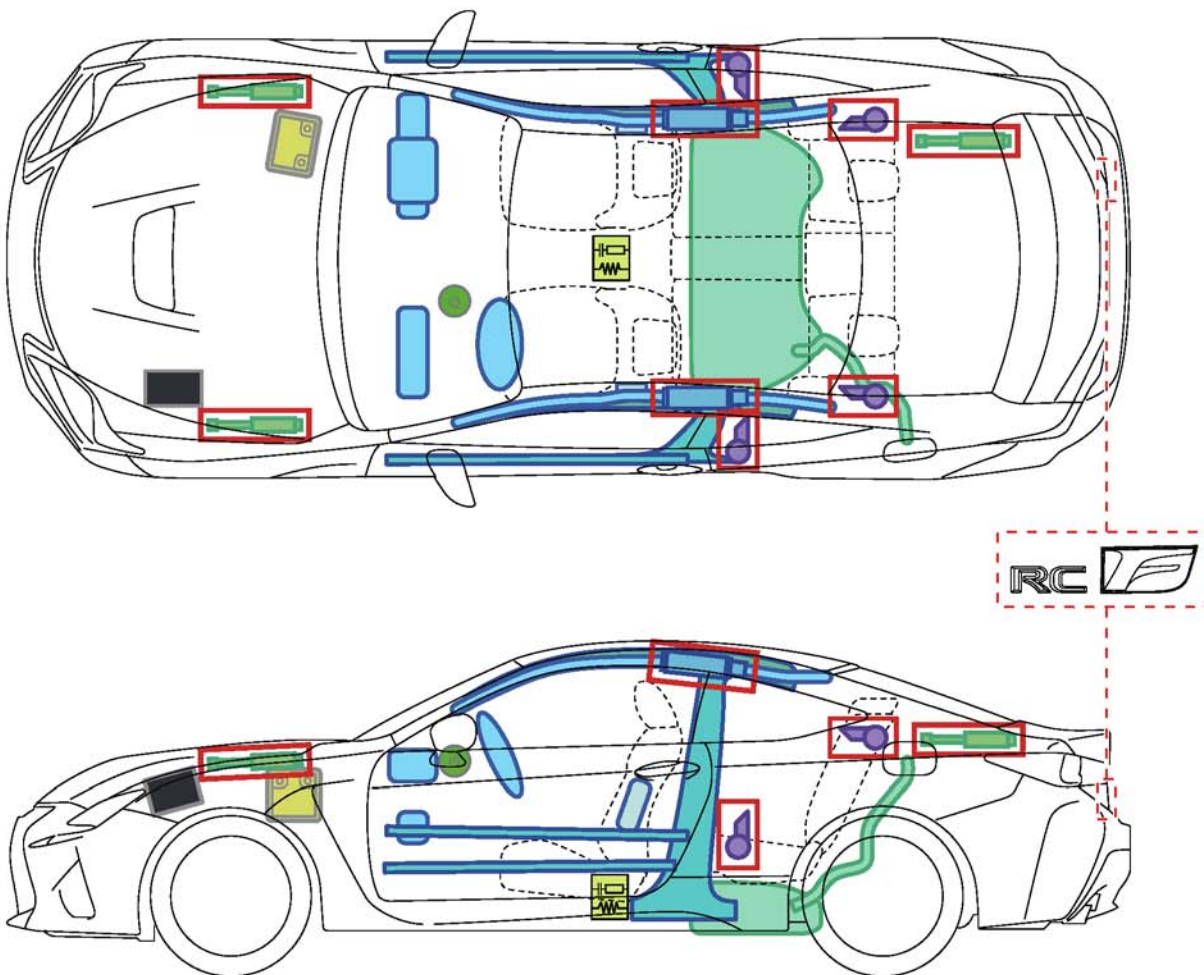





Lexus RC F

(UXC1 (EU, M), ab 09/2014)



Legende

	Zündschalter		Karosserie- verstärkung		Steuergerät
	Airbag		Gasdruck- dämpfer		12 Volt- Batterie
	Gas- generator		Kraftstoff- tank		
	Gurtstraffer		Sicherungs- kasten		

A

Lexus RC F (UXC1 (EU, ab 09/2014)

Lexus RC F (UXC1 (EU, M), ab 09/2014)



12V Spannungsversorgung trennen

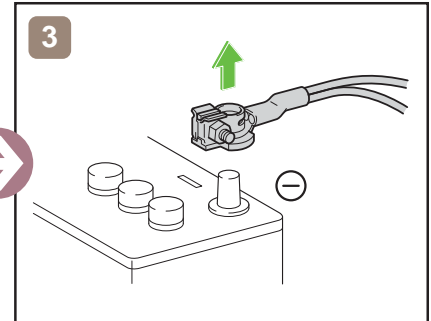
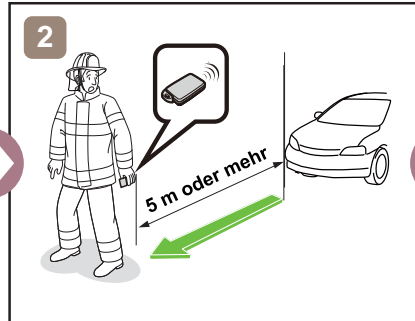
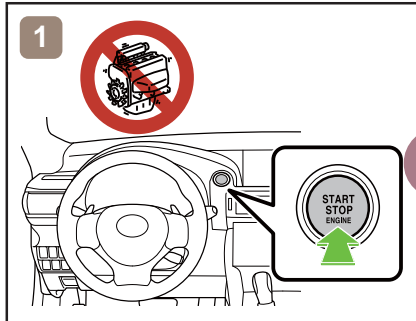

oder

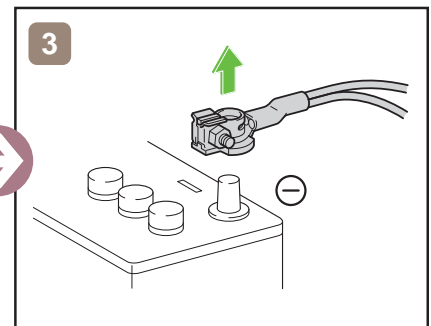
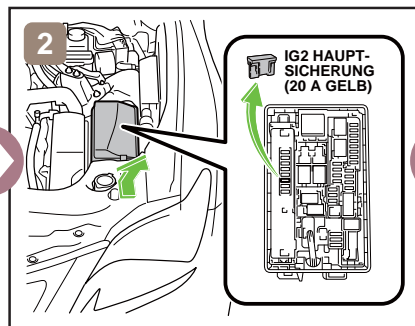
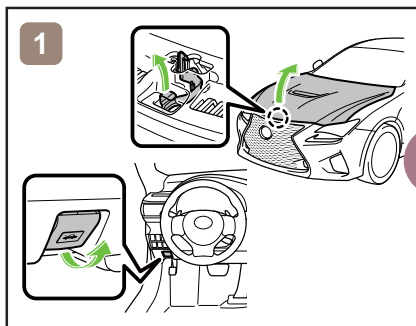

Zugang 12V Batterie

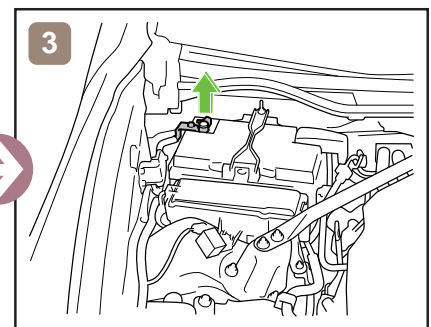
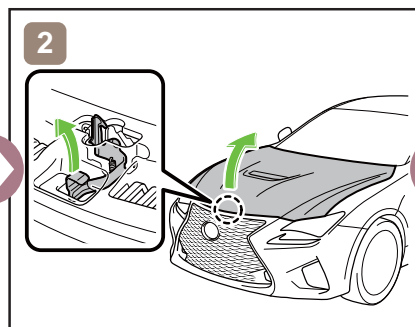
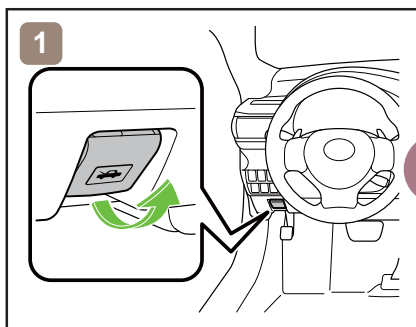

Hinweise zum Transport

